

VAISHNO COLLEGE OF ENGINEERING

Affiliated to HPTU, Hamirpur and approved by AICTE



Transportation Engineering

Lab Manual

CE-413P (NEP Syllabus)

Department of Civil Engineering

VillThapkour, PO Bhardoya, Tehsil Indora, Distt. Kangra (HP)-176403

Contact: 094183-18394, Web: www.vaishno.edu.in

Vision of Institute

To emerge as an institute of eminence in the fields of engineering, technology and management in serving the industry and the nation by empowering students with a high degree of technical managerial and practical competence.

Mission of Institute

M1 To strengthen the theoretical, practical and ethical dimensions of the learning process by fostering a cultural of research and innovation among faculty members and students.

M2 To encourage long term interaction between academia and industry through the involvement of industry for hands on implementation of the curriculum.

M3 To strengthen and molding students in professional ethical, social and environmental dimensions by encouraging participation in co-curricular extracurricular and CSR activities.

Vision of the Department

To produce engineers having professional and leadership qualities with capacity to take up professional and research assignments in Civil Engineering and allied fields with focus on inter-disciplinary and innovative approach and to compete at the global level.

Mission of the department

1. To impart quality and real time education to contribute to the field of Civil Engineering.
2. To impart soft skills, leadership qualities and professional ethics among the graduates to handle projects independently.
3. To develop graduates to compete at the global level.

Program Educational Objectives (PEOs) of the department

PEO1:- To impart quality education and knowledge in contemporary science and technology to meet the challenges in the field of Civil Engineering and to serve the society.

PEO2:- To impart the knowledge of analysis and design using the codes of practice and software packages.

PEO3:-To inculcate the sense of ethics, morality, creativity, leadership, professionalism, self confidence and independent thinking.

PEO4:- To motivate the students to take up higher studies and innovative research projects.

PROGRAM OUTCOMES

PO1: Engineering knowledge: Apply the knowledge of mathematics, science, engineering fundamentals, and an engineering specialization to the solution of complex engineering problems.

PO2: Problem analysis: Identify, formulate, research literature, and analyze complex engineering problems reaching substantiated conclusions using first principles of mathematics, natural sciences, and engineering sciences.

PO3: Design/development of solutions: Design solutions for complex engineering problems and design system components or processes that meet the specified needs with appropriate consideration for the public health and safety, and the cultural, societal, and environmental considerations.

PO4: Conduct investigations of complex problems: Use research-based knowledge and research methods including design of experiments, analysis and interpretation of data, and synthesis of the information to provide valid conclusions.

PO5: Modern tool usage: Create, select, and apply appropriate techniques, resources, and modern engineering and IT tools including prediction and modeling to complex engineering activities with an understanding of the limitations.

PO6: The engineer and society: Apply reasoning informed by the contextual knowledge to assess societal, health, safety, legal and cultural issues and the consequent responsibilities relevant to the professional engineering practice.

PO7: Environment and sustainability: Understand the impact of the professional engineering solutions in societal and environmental contexts, and demonstrate the knowledge of, and need for sustainable development.

PO8: Ethics: Apply ethical principles and commit to professional ethics and responsibilities and norms of the engineering practice.

PO9: Individual and team work: Function effectively as an individual, and as a member or leader in diverse teams, and in multidisciplinary settings.

PO10: Communication: Communicate effectively on complex engineering activities with the engineering community and with society at large, such as, being able to comprehend and write effective reports and design documentation, make effective presentations, and give and receive clear instructions.

PO11: Project management and finance: Demonstrate knowledge and understanding of the engineering and management principles and apply these to one's own work, as a member and leader in a team, to manage projects and in multidisciplinary environments.

PO 12: Life-long learning: Recognize the need for, and have the preparation and ability to engage in independent and life-long learning in the broadest context of technological change.

Program Specific Outcome (PSOs)

PSO 1: The graduates of this program will be able to meet the needs of public in the design and execution of quality construction work considering principles of mechanics, mathematics and physics to construct sustainable buildings that will ensure safety and durability till the service period.

PSO 2: The graduates will calculate the loads and the stresses acting on the building, analysis for the loads and design sections of structures to sustain the loads using building analysis software packages.

PSO 3: The graduates will be able to work effectively as an individual or in a team having acquired leadership skills and manage projects in multidisciplinary environments.

Lab Syllabus & List of Experiments

CEPC-413P Transportation Engineering Laboratory							
Teaching Scheme			Credit	Marks Distribution			Duration of End Semester Examination
L	T	P		Internal Assessment	End Semester Examination	Total	
0	0	2	1	Maximum Marks: 30	Maximum Marks: 20	50	2 Hours
				Minimum Marks: 12	Minimum Marks: 8	20	

Course Objectives:

- Road Aggregate Testing: Equip students with practical skills to conduct and analyze essential tests on road aggregates.
- Bituminous Material Evaluation: Train students to perform and interpret fundamental tests on bituminous materials.
- Pavement Evaluation Techniques: Enable students to conduct the CBR test and other pavement evaluations for design and maintenance.
- Traffic Studies and Highway Assessment: Develop skills in conducting traffic studies and inspecting highways to identify and suggest improvements.

Sr. No.	List of Experiments
	Tests on Road Aggregates: <i>(Perform minimum 03 tests)</i>
1	Aggregate Crushing Value Test: Measures the resistance of aggregate to crushing under a gradually applied compressive load.
2	Los Angeles Abrasion Test: Determines the abrasion resistance of aggregate by subjecting it to impact and grinding actions.
3	Aggregate Impact Test: Assesses the impact resistance of aggregates by measuring the percentage of crushed material.
4	Specific Gravity and Water Absorption Tests: Evaluates the density and water absorption capacity of aggregates.
5	Shape Test (Elongation & Flakiness): Identifies the shape characteristics of aggregates, which affect the workability and stability of pavements.
6	Stripping Value of Road Aggregate: Measures the resistance of aggregate to stripping in the presence of water, indicating its adhesion properties with bitumen.
	Tests on Bitumen: <i>(Perform minimum 03 tests)</i>
7	Penetration Test: Determines the hardness or softness of bitumen by measuring the depth a standard needle penetrates under specific conditions.

8	Softening Point Test: Identifies the temperature at which bitumen reaches a particular degree of softness, indicating its thermal susceptibility.
9	Specific Gravity Test: Measures the density of bitumen, which is essential for mix design calculations.
10	Viscosity Test: Assesses the flow characteristics of bitumen at different temperatures, crucial for understanding its behavior during mixing and compaction.
11	Ductility Test: Evaluates the ability of bitumen to undergo significant deformation without breaking, which is vital for its performance in pavements.
	Other Tests: (<i>Perform minimum 02 tests</i>)
12	California Bearing Ratio Test: Determines the strength of subgrade soil and pavement materials by measuring their resistance to penetration under controlled condition
13	Traffic Studies: Involves the collection and analysis of data related to traffic flow, volume,

Evaluation Scheme

Internal Assessment: 30 marks (pass marks:12)

Distribution of marks for internal assessment:

- Written/presentation/Demonstration: 05
- Viva-voice: 05
- Teacher assessment: Lab Work performance/Report/File Work:15
- Attendance: 05

External Assessment: 20 marks (pass marks: 08)

Total marks 30+20=50, Pass marks = 20

Note: Student has to pass internal & external assessment separately.

GENERAL GUIDELINES AND SAFETY INSTRUCTIONS

1. Sign in the log register as soon as you enter the lab and strictly observe your lab timings.
2. Strictly follow the written and verbal instructions given by the teacher / Lab Instructor. If you do not understand the instructions, the handouts and the procedures, ask the instructor or teacher.
3. Never work alone! You should be accompanied by your laboratory partner and / or the instructors / teaching assistants all the time.
4. It is mandatory to come to lab in uniform and wear your ID cards.
5. Do not wear loose-fitting clothing or jewellery in the lab. Rings and necklaces are usual excellent conductors of electricity.
6. Mobile phones should be switched off in the lab.
7. Keep the labs clean at all times, no food and drinks allowed inside the lab.
8. Intentional misconduct will lead to expulsion from the lab.
9. Do not handle any equipment without reading the safety instructions. Read the handout and procedures in the Lab Manual before starting the experiments.
10. Do your wiring, setup, and a careful circuit checkout before applying power. Do not make circuit changes or perform any wiring when power is on.
11. Avoid contact with energized electrical circuits.
12. Do not insert connectors forcefully into the sockets.
13. Never try to experiment with the power from the wall plug.
14. Immediately report dangerous or exceptional conditions to the Lab instructor / teacher: Equipment that is not working as expected, wires or connectors are broken, the equipment that smells or “smokes”. If you are not sure what the problem is or what's going on, switch off the Emergency shutdown.

15. Never use damaged instruments, wires or connectors. Hand over these parts to the Lab instructor/Teacher.
16. Be sure of location of fire extinguishers and first aid kits in the laboratory.
17. After completion of Experiment, return the bread board, trainer kits, wires, CRO probes and other components to lab staff. Do not take any item from the lab without permission.
18. Observation book and lab record should be carried to each lab. Readings of current lab experiment are to be entered in Observation book and previous lab experiment should be written in Lab record book. Both the books should be corrected by the faculty in each lab.

20. Special Precautions during soldering practice

- a. Hold the soldering iron away from your body. Don't point the iron towards you.
- b. Don't use a spread solder on the board as it may cause short circuit.
- c. Do not overheat the components as excess heat may damage the components/board.
- d. In case of burn or injury seek first aid available in the lab or at the college dispensary.

Experiment No: 1

1. OBJECTIVE

- 1) To determine the aggregate crushing value of coarse aggregates
- 2) To assess suitability of aggregates for use in different types of road pavement

2. PRINCIPLE

The aggregate crushing value gives a relative measure of the resistance of an aggregate to crushing under a gradually applied compressive load. Crushing value is a measure of the strength of the aggregate. The aggregates should therefore have minimum crushing value.

3. APPARATUS

The apparatus of the aggregate crushing value test as per IS: 2386 (Part IV) – 1963 consists of:

- 1) A 15cm diameter open ended steel cylinder with plunger and base plate, of the general form and dimensions as shown in Fig 1.
- 2) A straight metal tamping rod of circular cross-section 16mm diameter and 45 to 60 cm long, rounded at one end.
- 3) A balance of capacity 3k, readable and accurate up to 1 g.
- 4) IS Sieves of sizes 12.5,10 and 2.36 mm
- 5) A compression testing machine capable of applying a load of 40 tonnes and which can be operated to give a uniform rate of loading so that the maximum load is reached in 10 minutes. The machine may be used with or without a spherical seating
- 6) For measuring the sample, cylindrical metal measure of sufficient rigidity to retain its form under rough usage and of the following internal dimensions:

Diameter 11.5cm

Height 18.0cm

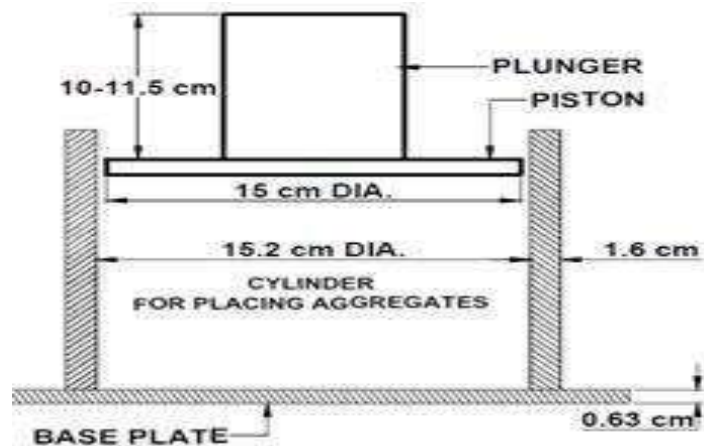

Fig 1 AGGREGATE CRUSHING TEST APPARATUS

4. PROCEDURE

The test sample: It consists of aggregates sized 12.5 mm - 10.0 mm (minimum 3kg). The aggregates should be dried by heating at 100-110° C for a period of 4 hours and cooled.

- 1) Sieve the material through 12.5 mm and 10.0 mm IS sieve. The aggregates passing through 12.5 mm sieve and retained on 10.0 mm sieve comprises the test material.
- 2) The cylinder of the test shall be put in position on the base-plate and the test sample added in thirds, each third being subjected to 25 strokes with the tamping rod.
- 3) The surface of the aggregate shall be carefully leveled.
- 4) The plunger is inserted so that it rests horizontally on this surface, care being taken to ensure that the plunger does not jam in the cylinder
- 5) The apparatus, with the test sample and plunger in position, shall then be placed between the plates of the testing machine.
- 6) The load is applied at a uniform rate as possible so that the total load is reached in 10 minutes. The total load shall be 40 tones.
- 7) The load shall be released and the whole of the material is removed from the cylinder and sieved on 2.36mm IS Sieve.
- 8) The fraction passing the sieve shall be weighed and recorded.

5. REPORTING OF RESULTS

The mean of the two results shall be reported to the nearest whole number as the 'aggregate crushing value' of the size of the material tested.

6. CONCLUSION

Aggregate Crushing test value =

Record of Observation

	Sample I	Sample II
Total weight of dry sample taken = W_1 gm		
Weight of portion passing 2.36 mm sieve = W_2 gm		
Aggregate crushing Value (per cent) = $(W_2/W_1)*100$		

Aggregate Crushing Mean Value =

Experiment No: 2

DETERMINATION OF AGGREGATE IMPACT VALUE

1. OBJECTIVE

- 1) To determine the impact value of the road aggregates
- 2) To assess suitability of aggregates for use in different types of road pavement

2. PRINCIPLE

The property of a material to resist impact is known as toughness. Due to movement of vehicles on the road the aggregates are subjected to impact resulting in their breaking down into smaller pieces. The aggregates should therefore have sufficient toughness to resist their disintegration due to impact. This characteristic is measured by impact value test. The aggregate impact value is a measure of resistance to sudden impact or shock, which may differ from its resistance to gradually applied compressive load.

3. APPARATUS

The apparatus of the aggregate impact value test as per IS: 2386 (Part IV) – 1963 consists of:

- 1) A testing machine weighing 45 to 60 kg and having a metal base with a plane lower surface of not less than 30 cm in diameter. It is supported on level and plane concrete floor of minimum 45 cm thickness. The machine should also have provisions for fixing its base.
- 2) A cylindrical steel cup of internal diameter 102 mm, depth 50 mm and minimum thickness 6.3 mm.
- 3) A metal hammer weighing 13.5 to 14.0 kg the lower end is cylindrical in shape, is 50 mm long, 100.0 mm in diameter, with a 2 mm chamfer at the lower edge and case hardened. The hammer should slide freely between vertical guides and be concentric with the cup. The free fall of the hammer should be within 380 ± 5 mm.
- 4) A cylindrical metal measure having internal diameter of 75 mm and depth 50 mm for measuring aggregates.
- 5) Tamping rod 10 mm in diameter and 230 mm long, rounded at one end.
- 6) A balance of capacity not less than 500 g, readable and accurate up to 0.1 g.

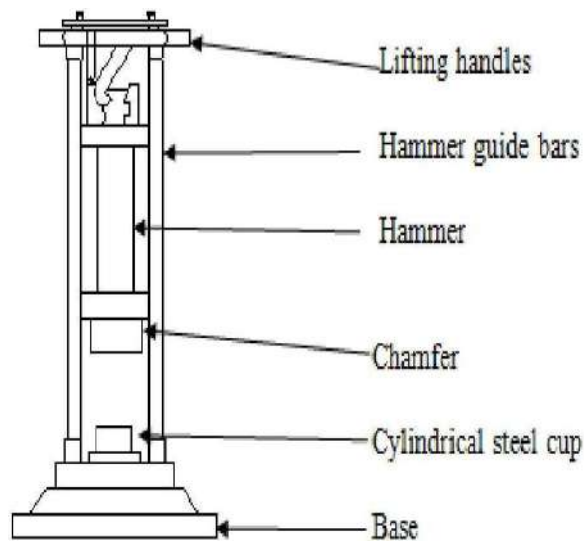

Fig 2 AGGREGATE IMPACT TESTING MACHINE

4. PROCEDURE

The test sample: It consists of aggregates sized 12.5 mm - 10.0 mm. The aggregates should be dried by heating at 100-110° C for a period of 4 hours and cooled.

- 1) Sieve the material through 12.5 mm and 10.0 mm IS sieve. The aggregates passing through 12.5 mm sieve and retained on 10.0 mm sieve comprises the test material.
- 2) Pour the aggregates to fill about 1/3rd depth of measuring cylinder.
- 3) Compact the material by giving 25 gentle blows with the rounded end of the tamping rod.
- 4) Add two more layers in similar manner, so that cylinder is full.
- 5) Strike off the surplus aggregates.
- 6) Determine the net weight of the aggregates to the nearest gram (W).
- 7) Bring the impact machine to rest without wedging or packing up on the level plate, block or floor, so that it is rigid and the hammer guide columns are vertical.
- 8) Fix the cup firmly in position on the base of machine and place whole of the test sample in it and compact by giving 25 gentle strokes with tamping rod.
- 9) Raise the hammer until its lower face is 380 mm above the surface of the aggregate sample in the cup and allow it to fall freely on the aggregate sample. Give 15 such blows at an interval of not less than one second between successive falls.

- 10) Remove the crushed aggregate from the cup and sieve it through 2.36 mm IS sieves until no further significant amount passes in one minute. Weigh the fraction passing the sieve to an accuracy of 1 gm (W_2). Also weigh the fraction retained in the sieve.
- 11) Note down the observations in the Performa and compute the aggregate impact value.

The mean of two observations, rounded to nearest whole number is reported as the Aggregate Impact Value.

1. PRECAUTIONS

- 1) Place the plunger centrally so that it falls directly on the aggregate sample and does not touch the walls of the cylinder in order to ensure that the entire load is transmitted on to the aggregates.
- 2) In the operation of sieving the aggregates through 2.36 mm sieve the sum of weights of fractions retained and passing the sieve should not differ from the original weight of the specimen by more than 1 gm.
- 3) The tamping is to be done properly by gently dropping the tamping rod and not by hammering action. Also the tamping should be uniform over the surface of the aggregate taking care that the tamping rod does not frequently strike against the walls of the mould.

2. REPORTING OF RESULTS

The mean of the two results shall be reported to the nearest whole number as the aggregate impact value of the tested material.

Aggregate impact value is used to classify the stones in respect of their toughness property as indicated below in Table 1.

Table 1: Classification of aggregate based on aggregate impact value

Aggregate impact value (%)	Quality of aggregate
< 10	Exceptionally strong
10 – 20	Strong
20 – 30	Satisfactory for road surfacing

>35	Weak for road surfacing
-----	-------------------------

Table 2: Maximum allowable impact values of aggregate in different types of Pavement material/ layers

Sl. No	Types of pavement material /layer	Aggregate impact value (%)
1	Water bound macadam, sub-base course	50
2	Cement concrete, base course	45
3	i) WBM base coarse with bitumen surfacing ii) Built-up spray grout, base course	40
4	Bituminous macadam, base course	35
5	i) WBM, surfacing course ii) Built-up spray grout, surfacing course iii) Bituminous penetration macadam iv) Bituminous surface dressing v) Bituminous macadam, binder course vi) Bituminous carpet vii) Bituminous/Asphaltic concrete viii) Cement concrete, surface course	30

1. CONCLUSION

Record of Observation	Sample I	Sample II
Total weight of dry sample taken= W_1 gm		
Weight of portion passing 2.36 mm sieve = W_2 gm		
Aggregate impact = $(W_2/W_1)*100$ Value (per cent)		

Aggregate Impact Mean Value =

Experiment No: 3

A. FLAKINESS INDEX

Aim:

This method of test lays down the procedure for determining the flakiness index of the coarse aggregate.

1. PRINCIPLE

The flakiness index of an aggregate is the percentage by weight of particles in it whose least dimension (thickness) is less than three-fifths of their mean dimension. The test is not applicable to sizes smaller than 6.3mm.

2. APPARATUS

The apparatus shall consist of the following:

1) A balance – The balance shall be of sufficient capacity and sensitivity and shall have an accuracy of 0.1 percent of the weight of the test sample

Metal Gauge – The metal gauge shall be of the pattern as shown in Fig 4

Sieves – The sieves of sizes as shown in Table 6.

3. PROCEDURE

1) A quantity of aggregate shall be taken sufficient to provide the minimum number of 200 pieces of any fraction to be tested.

2) The sample shall be sieved with sieves specified in Table 6.

3) Then each fraction shall be gauged in turn for thickness on a metal gauge of the pattern shown in Fig 4 or in bulk on sieves having elongated slots. The width of the slot used in the gauge or sieve shall be of the dimensions specified in column 3 of Table 6 for the appropriate size of material.

4) The total amount of aggregate passing the gauge shall be weighed to an accuracy of at least 0.1 percent of the weight of the test sample

SIZE OF AGGREGATE (mm)		THICKNESS GAUGE(mm) *	LENGTH GAUGE(mm) #
Passing through IS sieve	Retained on IS sieve		
63	50	33.90	-
50	40	27.00	81.0
40	31.5	19.50	58.5
31.5	25	16.95	-
25	20	13.50	40.5
20	16	10.80	32.4
16	12.5	8.55	25.6
12.5	10	6.75	20.2
10	6.3	4.89	14.7

Table6. Dimensions of Thickness and Length gauge

*This dimension is equal to 0.6 times the mean sieve size. # This

dimension is equal to 1.8 times the mean sieve size.

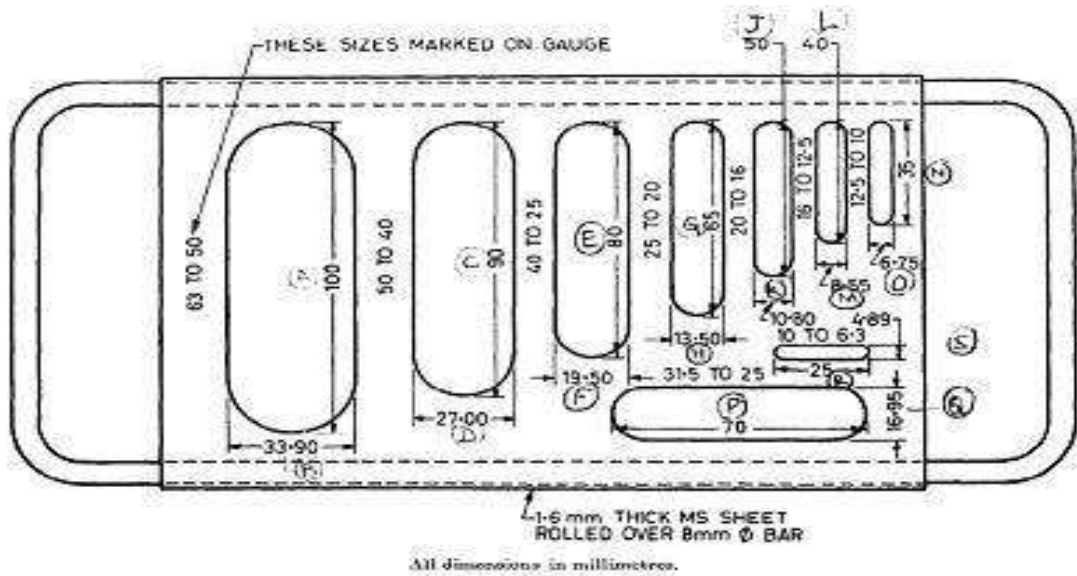

Fig4. THICKNESS GAUGE

4. CALCULATION

Flakiness index = $100 \frac{w}{W}$ %

Where, w is the weights of material passing the various thickness gauges and W is the total weights of aggregate passing and retained on the specified sieves.

5. REPORTING OF RESULTS

The flakiness index is the total weight of the material passing the various thickness gauges, expressed as the percentage of the total weight of the sample gauged.

6. CONCLUSION

Flakiness index =

B. ELONGATION INDEX

1. OBJECTIVE

This method of test lays down the procedure for determining the elongation index of the coarse aggregate.

2. PRINCIPLE

The elongation index of an aggregate is the percentage by weight of particles in it whose greatest dimension (thickness) is greater than one and four-fifths of their mean dimension. The test is not applicable to sizes smaller than 6.3mm.

3. APPARATUS

The apparatus shall consist of the following:

- 4) A balance – The balance shall be of sufficient capacity and sensitivity and shall have an accuracy of 0.1 percent of the weight of the test sample
- 5) Metal Gauge – The metal gauge shall be of the pattern as shown in Fig 5
- 6) Sieves – The sieves of sizes as shown in Table 6.

4. PROCEDURE

- 5) A quantity of aggregate shall be taken sufficient to provide the minimum number of 200 pieces of any fraction to be tested.
- 6) The sample shall be sieved with sieves specified in Table 6.
- 7) Each fraction shall be gauged in turn for length on a metal gauge of the pattern

shown in Fig 5. The gauge length used shall be of the dimensions specified in column 4 of Table 6 for the appropriate size of material.

8) The total amount of aggregate retained by the length gauge shall be weighed to an accuracy of at least 0.1 percent of the weight of the test sample

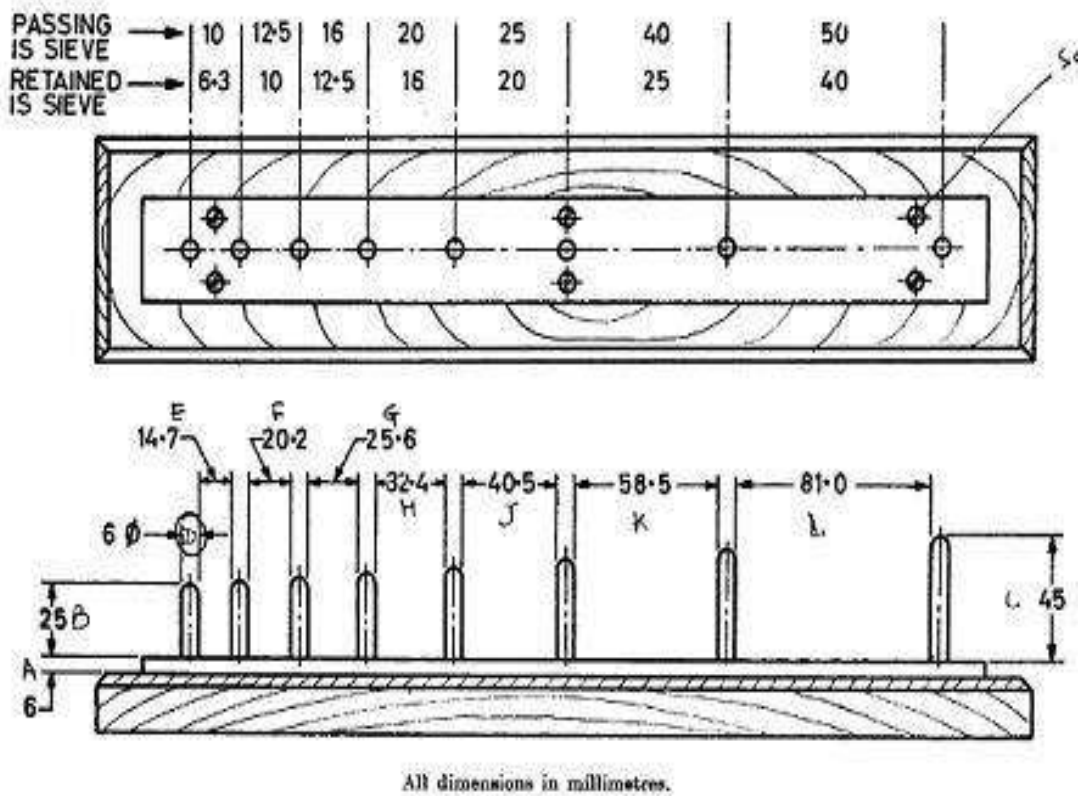

Fig5. LENGTH GAUGE

5. CALCULATION

$$\text{Elongation index} = 100 \%$$

Where, x is the weight of materials retained on specified gauges

W is the total weights of aggregate passing and retained on the specified sieves.

6. REPORTING OF RESULTS

The elongation index is the total weight of the material retained on various length gauges, expressed as the percentage of the total weight of the sample gauged.

7. CONCLUSION

Elongation index =

Experiment No. 4

DETERMINATION OF LOS ANGELES ABRASION VALUE

1. OBJECTIVE

- 1) To determine Los Angeles abrasion value.
- 2) To find out the suitability of aggregates for its use in road construction.

2. PRINCIPLE

The aggregates used in surface course of the highway pavements are subjected to wearing due to movement of traffic. When vehicles move on the road, the soil particles present between the pneumatic tyres and road surface causes abrasion of road aggregates. The steel reamed wheels of animal driven vehicles also cause considerable abrasion of the road surface. Therefore, the road aggregate should be hard enough to resist the abrasion. Resistance to abrasion of aggregates is determined in laboratory by Los Angeles test machine.

The principle of Los Angeles abrasion test is to produce the abrasive action by use of standard steel balls which when mixed with the aggregates and rotated in a drum for specific number of revolutions also causes impact on aggregates. The percentage wear of the aggregates due to rubbing with steel balls is determined and is known as Los Angeles Abrasion Value.

3. APPARATUS

The apparatus as per IS: 2386 (Part IV) – 1963 consists of:

- 1) Los Angeles Machine: It consists of a hollow steel cylinder, closed at both the ends with an internal diameter of 700 mm and length 500 mm and capable of rotating about its horizontal axis. A removable steel shaft projecting radially 88 mm into cylinder and extending full length (i.e. 500 mm) is mounted firmly on the interior of cylinder. The shelf is placed at a distance 1250 mm minimum from the opening in the direction of rotation.
- 2) Abrasive charge: Cast iron or steel balls, approximately 48 mm in diameter and each weighing between 390 to 445 g; 6 to 12 balls are required.
- 3) Sieve: The 1.70 mm IS sieve
- 4) Balance of capacity 5 kg or 10 kg
- 5) Drying oven
- 6) Miscellaneous like tray etc

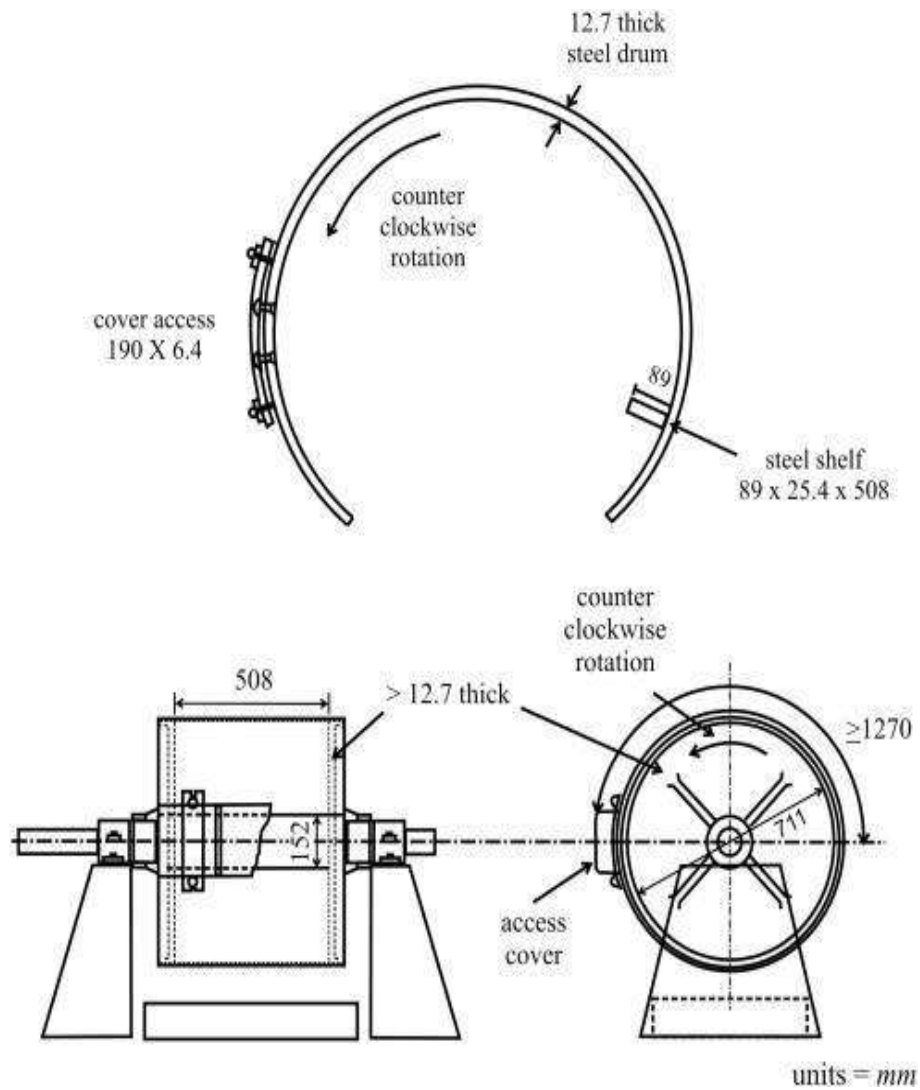

Fig 3 LOS ANGELES ABRASION TESTING MACHINE

4. PROCEDURE

Test Sample: It consists of clean aggregates dried in oven at 105 - 110° C and coarser than 1.70 mm sieve size. The sample should conform to any of the grading shown in table.

Table 3 Grading of Test Samples

Sieve size (square hole)		Weight in g of Test Sample for Grade						
Passing mm	Retained on mm	A	B	C	D	E	F	G
80	63	-	-	-	-	2500*	-	-
63	50	-	-	-	-	2500*	-	-
50	40	-	-	-	-	5000*	5000*	-
40	25	1250	-	-	-	-	5000*	5000*
25	20	1250	-	-	-	-	-	5000*
20	12.5	1250	2500	-	-	-	-	-
12.5	10	1250	2500	-	-	-	-	-
10	6.3	-	-	2500	-	-	-	-
6.3	4.75	-	-	2500	-	-	-	-
4.75	2.36	-	-		5000	-	-	-

*Tolerance of ± 12 percent permitted.

- 1) Select the grading to be used in the test. It should be chosen such that it conforms to the grading to be used in construction, to the maximum extent possible.
- 2) Take 5 kg of sample for grading A, B, C or D and 10 kg for grading E, F and G.
- 3) Choose the abrasive charge as per Table 2.

Table 4 Selection of Abrasive Charges

Grading	No. of Steel balls	Weight of charge, g
A	12	5000 \pm 25
B	11	4584 \pm 25
C	8	3330 \pm 25
D	6	2500 \pm 25

E	12	5000 ± 25
---	----	-----------

The test sample and the abrasive charge shall be placed in the Los Angles abrasion testing machine.

- 1) The machine is rotated at a speed of 20 to 33 rev/min for grading A, B,C and D, the machine shall be rotated for 500 revolutions; for grading E, F and G, it shall be rotated for 1000 revolutions
- 2) The material is discharged from the machine after the completion of the test and is sieved through 1.7 mm IS sieve.
- 3) The weight of the aggregate passing through 1.7mm sieve is taken and recorded

5. REPORTING OF RESULTS

The difference between the original weight and the final weight of the test sample shall be expressed as a percentage of the original weight of the test sample. This value is reported as the percentage wear.

Table 5. Maximum L A Abrasion values of aggregates in different types of pavement layers

Sl no.	Types of pavement layer	Maximum Los Value (%)
1	Water bound macadam ,sub-base course	60
2	i) WBM base course with bituminous surfacing ii) Bituminous macadam base course iii) Built-up spray grout base course	50
3	i) WBM surfacing course ii) Bituminous macadam binder course iii) Bituminous penetration macadam iv) Built-up spray grout binder course	40
4	i) Bituminous carpet surface course ii) Bituminous surface dressing, single or two coats iii) Bituminous surface dressing, using pre-coated aggregates	35
5	i) Bituminous concrete surface course ii) Cement concrete pavement surface course	30

6. CONCLUSION

Los Angeles Abrasion value =

	Sample I	Sample II
Total weight of dry sample taken= W_1 gm		
Weight of portion passing 1.7 mm sieve= W_2 gm		
Aggregate abrasion value = $(W_2/W_1)*100$ Value (per cent)		

Mean Los Angeles Abrasion value =

Experiment No. 5

DETERMINATION OF PENETRATION VALUE OF BITUMEN

1. OBJECTIVE

To determine the consistency of bituminous material

2. PRINCIPLE

Penetration value is a measurement of hardness or consistency of bituminous material. It is the vertical distance traversed or penetrated by the point of a standard needle in to the bituminous material under specific conditions of load, time, and temperature. This distance is measured in one tenth of a millimeter. This test is used for evaluating consistency of bitumen. It is not regarded as suitable for use in connection with the testing of road tar because of the high surface tension exhibited by these materials and the fact that they contain relatively large amount of free carbon.

3. APPARATUS

1. Container A flat bottomed cylindrical metallic dish 55 mm in diameter and 35 mm in depth is required. If the penetration is of the order of 225 or more deeper dish of 70 mm diameter and 45 mm depth is required.
2. Needle: A straight, highly polished, cylindrical hard steel rod, as per standard dimensions
3. Water bath: A water bath maintained at $25.0 \pm 0.1^{\circ}\text{C}$ containing not less than 10 litres of water, the sample being immersed to a depth not less than 100 mm from the top and supported on a perforated shelf not less than 50 mm from the bottom of the bath.
4. Transfer dish or tray: It should provide support to the container and should not rock the container. It should be of such capacity as to completely immerse the container during the test.
5. Penetration apparatus: It should be such that it will allow the needle to penetrate without much friction and is accurately calibrated to give results in one tenth of a milli metre
6. Thermometer: Range 0- 44°C and readable up to 0.2°C
7. Time measuring device: With an accuracy ± 0.1 sec

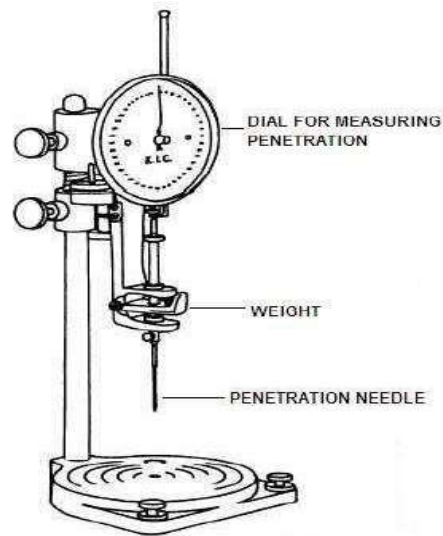

Fig6. PENETROMETER

4. PROCEDURE

- 1) Preparation of test specimen: Soften the material to a pouring consistency at a temperature not more than 60°C for tars and 90°C for bitumen's above the approximate softening point and stir it thoroughly until it is homogeneous and is free from air bubbles and water. Pour the melt into the container to a depth at least 10 mm in excess of the expected penetration. Protect the sample from dust and allow it to cool in an atmosphere at a temperature between 15 to 30°C for one hour. Then place it along with the transfer dish in the water bath at $25 \pm 0.1^\circ\text{C}$, unless otherwise stated.
- 2) Fill the transfer dish with water from the water bath to depth sufficient to cover the container completely, place the sample in it and put it upon the stand of the penetration apparatus.
- 3) Clean the needle with benzene, dry it and load with the weight. The total moving load required is $100 \pm 0.25\text{gms}$, including the weight of the needle, carrier and super-imposed weights.
- 4) Adjust the needle to make contact with the surface of the sample. This may be done by placing the needle point in contact with its image reflected by the surface of the bituminous material

- 5) Make the pointer of the dial to read zero or note the initial dial reading.
- 6) Release the needle for exactly five seconds
- 7) Adjust the penetration machine to measure the distance penetrated.
- 8) Make at least 3 readings at points on the surface of the sample not less than 10 mm apart and not less than 10 mm from the side of the dish. After each test return the sample and transfer dish to the water bath and wash the needle clean with benzene and dry it. In case of material of penetration greater than 225, three determinations on each of the two identical test specimens using a separate needle for each determination should be made, leaving the needle in the sample on completion of each determination to avoid disturbance of the specimen.

5. CONCLUSION

Penetration value of given sample is =

Record of Observations

Actual Test Temperature =

		Test 1	Test 2	Test 3	Mean
Penetrometer dial reading	Initial				
	Final				
Penetration value					

Penetration value =

Experiment No. 6

DETERMINATION OF SOFTENING POINT OF BITUMINOUS MATERIAL

1. OBJECTIVE

To determine the softening point of bitumen or tar

2. PRINCIPLE

The softening point of bitumen or tar is the temperature at which the substance attains a particular degree of softening. As per IS:334-1982, it is the temperature (in °C) at which a standard ball passes through a sample of bitumen in a mould and falls through a height of 2.5 cm, when heated under water or glycerin at specified conditions of test. The binder should have sufficient fluidity before its applications in road uses. The determination of softening point helps to know the temperature up to which a bituminous binder should be heated for various road use applications. Softening point is determined by ring and ball apparatus.

3. APPARATUS

1. Steel balls-two numbers each of 9.5 mm dia. and weighing $3.5 \pm 0.05\text{g}$.
2. Brass rings-two numbers each having depth of 6.4 mm. The inside diameter at bottom and top is 15.9 mm and 17.5 mm respectively.
3. Ball guides to guide the movement of steel balls centrally.
4. Support- that can hold rings in position and also allows for suspension of a thermometer. The distance between the bottom of the rings and the top surface of the bottom plate of the support is 25 mm.
5. Thermometer that can read up to 100°C with an accuracy of 0.2° C
6. Bath- A heat resistant glass beaker not less than 85 mm in diameter and 1220 mm in depth.
7. Stirrer.

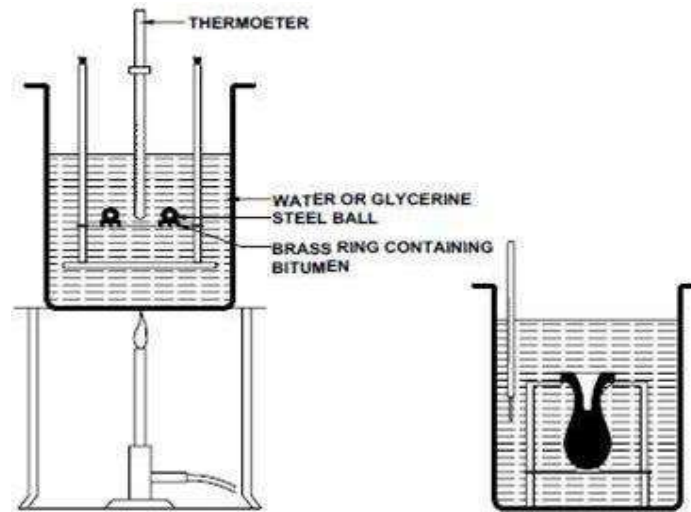

Fig7. ASSEMBLY OF APPARATUS FOR DETERMINATION OF SOFTENING POINT (RING & BALL)

4. PROCEDURE

1. Heat the material to a temperature between 75-100°C above its softening point stir until, it is completely fluid and free from air bubbles and water. If necessary filter it through IS Sieve 30. Place the rings, previously heated to a temperature approximating to that of the molten material, on a metal plate which has been coated with a mixture of equal parts of glycerin and dextrin. After cooling for 30 minutes in air, level the material in the ring by removing the excess with a warmed, sharp knife.

2. Assemble the apparatus with the rings, thermometer and ball guides in position.

3. Fill the bath with distilled water to a height of 50 mm above the upper surface of the rings. The starting temperature should be 5°C.

Note: Use glycerin in place of water if the softening point is expected to be above 80 ° C the starting temperature may be kept 35° C.

4. Apply heat to the bath and stir the liquid so that the temperature rises at a uniform rate of 5±0.5°C per minute.

5. As the temperature increases the bituminous material softens and the ball sinks through the ring, carrying a portion of the material with it.

6. Note down the temperature when any of the steel ball with bituminous coating

touches the bottom plate.

7. Record the temperature when the second ball also touches the bottom plate. The average of the two readings to the nearest 0.5°C is reported as the softening point.

5. PRECAUTIONS

- 1 Distilled water should be used as the heating medium.
- 2 During the conduct of test the apparatus should not be subjected to vibrations.
- 3 The bulb of the thermometer should be at about the same level as the rings.

6. CONCLUSION

The softening point of given sample is =

Record of Observations

Temperature when the ball touches bottom in °C	1	2	Average

Softening point of the bituminous material =

Experiment No. 7

DETERMINATION OF DUCTILITY OF BITUMEN

1. OBJECTIVE

1. To measure the ductility of a given sample of bitumen.

2. PRINCIPLE

The ductility test gives a measure of adhesive property of bitumen and its ability to stretch. In a flexible pavement design, it is necessary that binder should form a thin ductile film around the aggregates so that the physical interlocking of the aggregates is improved. Binder material having insufficient ductility gets cracked when subjected to repeated traffic loads and it provides pervious pavement surface. Ductility of a bituminous material is measured by the distance in centimeters to which it will elongate before breaking when two ends of standard briquette specimen of the material are pulled apart at a specified speed and at a specified temperature.

3. APPARATUS

1. Briquette mould: It is made up of brass. The circular holes are provided in the clips to grip the fixed and movable ends of the testing machine. The moulds when properly assemble form a briquette specimen of the following dimensions.

Total length 75.0 ± 0.5 mm

Distance between clips 30.0 ± 0.3 mm Width

at mount of slip 20.0 ± 0.2 mm

Width at minimum cross-section (half way between clips) 10.0 ± 0.1 mm Thickness

throughout 10.0 ± 0.1 mm

2. Water bath. A bath maintained within $\pm 0.1^\circ\text{C}$ of the specified test temperature, containing not less than 10 litres of water, the specimen being submerged to a depth of not less than 10 cms and supported on a perforated shelf and less than 5 cms. from the bottom of the bath.

3. Testing machine. For pouring the briquette of bituminous material apart, any apparatus may be used which is so constructed that the specimen will be continuously submerged in water while the two clips are being pulled apart horizontally at a uniform speed of 50 ± 2.5 mm per minute.

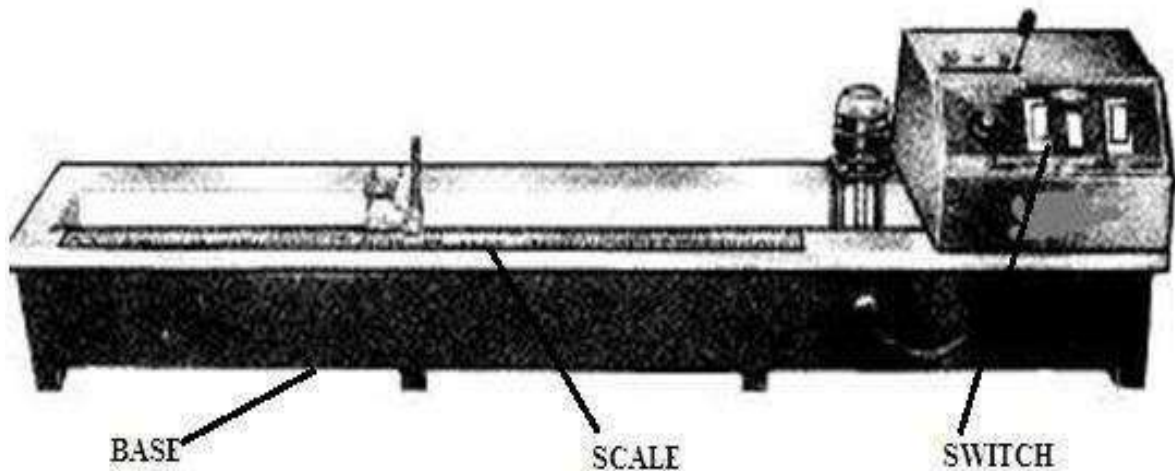

Fig 9. DUCTILITY TESTING MACHINE

4. PROCEDURE

- 1) Melt the bituminous test material completely at a temperature of 75°C to 100°C Above the approximate softening point until it becomes thoroughly fluid.
- 2) Strain the fluid. Through IS sieve 30.
- 3) After stirring the fluid, pour it in the mould assembly and place it on a brass plate.
- 4) In order to prevent the material under test from sticking, coat the surface of the plate and interior surfaces of the sides of the mould with mercury or by a mixture of equal parts of glycerine and dextrin.
- 5) After about 30-40 minutes, keep the plate assembly along with the sample in a water bath. Maintain the temperature of the water bath at 27°C for half an hour.

- 7) Remove the sample and mould assembly from the water bath and trim the specimen by levelling the surface using a hot knife. Replace the mould assembly in water bath maintained at 27° C for 80 to 90 minutes.
 - 8) Remove the sides of the mould.
 - 9) Hook the clips carefully on the machine without causing any initial stain.
 - 10) Adjust the pointer to read zero.
 - 11) Start the machine and pull two clips horizontally at a speed of 50 mm per minute.
 - 12) Note the distance at which the bitumen thread of specimen breaks.
 - 13) Record the observations in the Performa and compute the ductility value.
- Report the mean of two observation, rounded to nearest whole number as the 'Ductility Value'

Note: machine may have a provision to fix two or more moulds so as to test these specimens simultaneously.

5. PRECAUTIONS

- 1 The plate assembly upon which the mould is placed shall be perfectly flat and level so that the bottom surface of the mould touches it throughout.
- 2 In filling the mould, care should be taken not to disarrange the parts and thus distort the briquette and to see that no air pocket shall be within the molded sample.

6. CONCLUSION

The ductility value of given sample is =

Record of Observations

Bitumen grade

=

Reading	Briquette No			Mean
	1	2	3	
Initial				
Final				
Ductility in cm				

Experiment No. 8

STRIPPING VALUE OF AGGREGATE

1. OBJECTIVE

To find out the stripping value of the road aggregates

2. PRINCIPLE

The film stripping device is used to measure resistance of bituminous mixtures to stripping of the bitumen from the rock particles and is generally used to evaluate the mineral aggregate. However, it may be used to judge the adhesive capacity of the bituminous material. Stone screenings for use in seal coats or open graded mixes are usually subjected to this test. The test is applied to the aggregate fraction passing 10mm sieve and retained on 2.36mm sieve. Four specimens can be tested simultaneously.

3. APPARATUS

Film Stripping Apparatus: Four bottles are positioned in the rotating drum. The rotating drum is connected to a gear box which is coupled to a motor. The drum rotates at the rate of approximately 100rpm.

4. PROCEDURE

- 1) Coat 60g sample of aggregate which passes through 10mm IS Sieves and retained on 2.36mm IS Sieve with the bitumen to be tested.
- 2) Keep it in the bottle and cure the sample for 15hours at 60°C.
- 3) Allow it to cool to room temperature at 25°C.
- 4) Add 175ml of distilled water.
- 5) Similarly take the specimens in the other three bottles and screw on the caps to the bottles having the rubber gasket in between the bottle top and the cap. Clamp the bottles to the disc.
- 6) Switch on the unit and agitate the mixture for 15 minutes.
- 7) Estimate the percentage of aggregate stripped by visual observation.

5. PRECAUTIONS

Keep the bottles and washers clean. When not in use keep the bottles mounted in the position as shown in Fig 8.

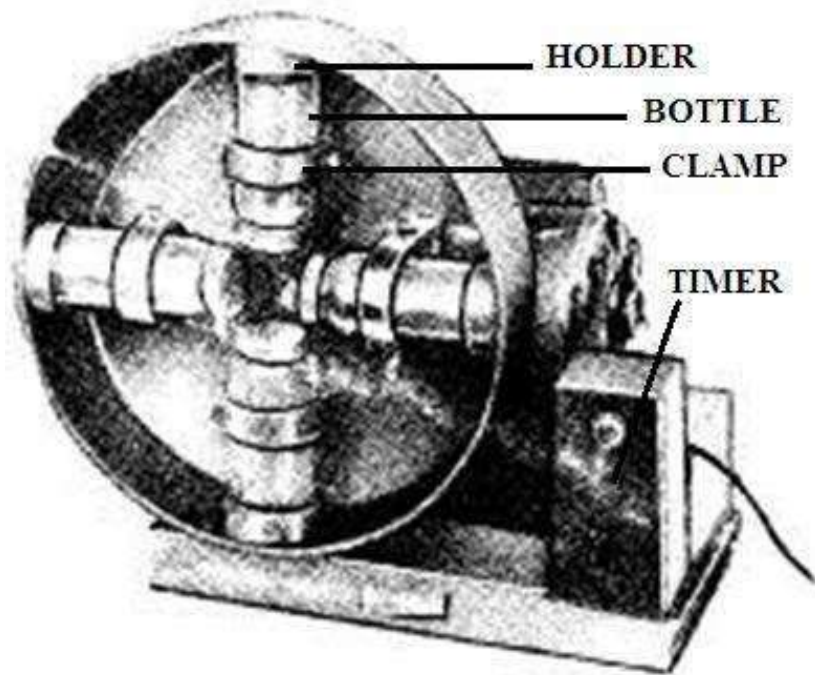

6. CONCLUSION

The Stripping value of aggregate

Laboratory Experiment Evaluation Rubric

Category	Outstanding (Up to 100%)	Accomplished (Up to 75%)	Developing (Up to 50%)	Beginner (Up to 25%)
Written/Presentation/Demonstration	The write-up is clear, well-organized, and follows the prescribed format. All required sections (aim, apparatus, theory, procedure, diagram, etc.) are present and well-written. Demonstration is clear and thorough.	The report follows the specified format, but some sections (like the diagram or theory) are missing or incomplete. The demonstration is understandable but lacks depth.	The report includes most sections but lacks clarity, coherence, or completeness in some parts (e.g., diagram missing, unclear theoretical explanation). The demonstration is incomplete or unclear.	The report is poorly written and organized. Many sections are missing or incorrect (e.g., no diagram, incomplete procedure). The demonstration lacks clarity or is missing.
Viva-Voice	Demonstrates a deep understanding of the experiment, underlying principles, and outcomes. Answers questions confidently	Demonstrates a general understanding of the experiment and principles but struggles with some aspects. Provides correct answers to	Struggles with some fundamental concepts and principles. Answering questions requires additional prompts, with a few errors in	Lacks a basic understanding of the experiment. Unable to answer most questions accurately. Demonstrates significant gaps in knowledge.

Category	Outstanding (Up to 100%)	Accomplished (Up to 75%)	Developing (Up to 50%)	Beginner (Up to 25%)
	and accurately.	most questions.	understanding.	
Performance/Report/File Work	Performs the experiment accurately and efficiently. The report is thorough, with correct observations, calculations, and analysis. Data is recorded neatly and with appropriate units. All relevant calculations and interpretations are included.	Performs the experiment well with minor errors or delays. The report is complete but may contain some inaccuracies or missing components in calculations or observations.	Completes the experiment but with notable mistakes, either in the setup or the data. The report has several missing or inaccurate components, including incorrect or incomplete calculations.	Struggles to perform the experiment correctly. Significant errors in setup, data collection, and analysis. The report is poorly structured with major inaccuracies or missing sections.
Attendance	Consistently attends all lab sessions, actively participates, and engages with the experiment	Attends most lab sessions with occasional absences. Participation is generally good but lacks	Attends some lab sessions but has frequent absences or minimal participation.	Misses several lab sessions and shows minimal to no participation in class or

Category	Outstanding (Up to 100%)	Accomplished (Up to 75%)	Developing (Up to 50%)	Beginner (Up to 25%)
	and group discussions.	consistency or depth.		group activities.